

FEMALE RIGHT ANGLE CABLE PLUG-CRIMP TYPE

R210.158.010

CABLE 2.6/50 D-BR

Series : MMT

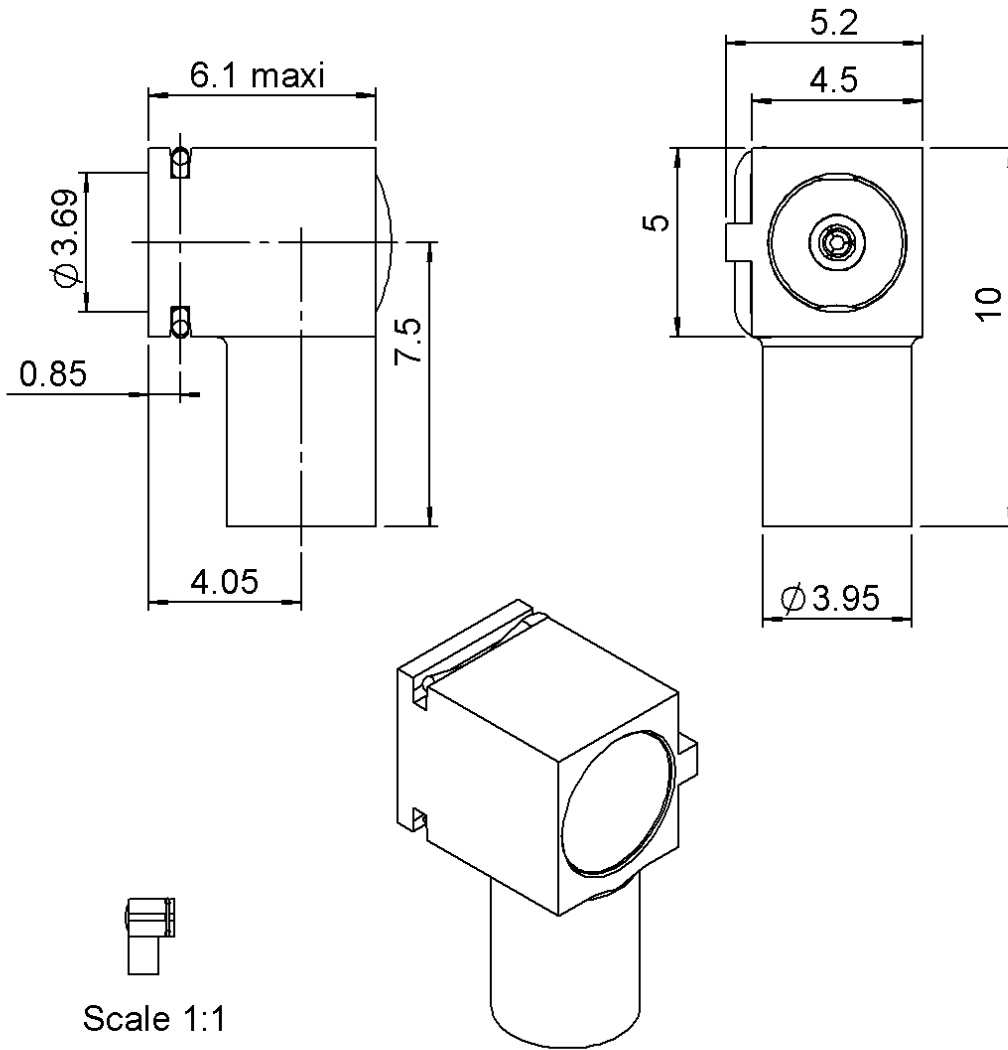

All dimensions are in mm.

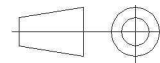

COMPONENTS	MATERIALS	PLATING (µm)
BODY	BRASS	NICKEL 2
CENTER CONTACT	BERYLLIUM COPPER	OR 0.5 SUR NICKEL 2
OUTER CONTACT	BRASS	NICKEL 2
INSULATOR	PTFE	
GASKET		
OTHERS PARTS	BRASS	NICKEL
-	-	-
-	-	-

Issue : 0729 A

In the effort to improve our products, we reserve the right to make changes judged to be necessary.



FEMALE RIGHT ANGLE CABLE PLUG-CRIMP TYPE

R210.158.010

CABLE 2.6/50 D-BR

Series : MMT

PACKAGING

Standard	Unit	Other
100	'W' option	Contact us

SPECIFICATION

ELECTRICAL CHARACTERISTICS

Impedance		50 Ω
Frequency		0-8 GHz
VSWR	1.10 +	0,0500 x F(GHz) Maxi
Insertion loss		0.2 √F(GHz) dB Maxi
RF leakage	- (- F(GHz)) dB Maxi
Voltage rating		170 Veff Maxi
Dielectric withstanding voltage		500 Veff mini
Insulation resistance		5000 MΩ mini

CABLE ASSEMBLY

Stripping	a	b	c	d	e	f
mm	2,50	2,00	0,00	0,00	4,50	0,00

Assembly instruction : **Crimp 06**

Recommended cable(s)
K02252D
RD 316

Characteristics indicated on this data sheet are those that can be achieved with the highest performance cable. Intrinsic limitations of the cable may diminish the performance of the assembly

Cable retention

- pull off **60** N mini
- torque - N.cm

MECHANICAL CHARACTERISTICS

Center contact retention		
Axial force – Mating end	8	N mini
Axial force – Opposite end	NA	N mini
Torque	NA	N.cm mini

TOOLING

Part Number	Description	Hexagon
.	.	.

Recommended torque		
Mating	-	N.cm
Panel nut	-	N.cm
Clamp nut	-	N.cm
A/F clamp nut	0,0000	mm

OTHER CHARACTERISTICS

Accouplt: 18Nmax / desacc.: 7Nmin

Mating life	500	Cycles mini
Weight	0,9800	g

ENVIRONMENTAL

Operating temperature	-55/+100	° C
Hermetic seal	-	Atm.cm3/s
Panel leakage	-	

Issue : 0729 A

In the effort to improve our products, we reserve the right to make changes judged to be necessary.



FEMALE RIGHT ANGLE CABLE PLUG-CRIMP TYPE**R210.158.010****CABLE 2.6/50 D-BR**

Series : MMT

A SPECIAL TOOL MUST BE USED TO REMOVE THE RIGHT ANGLE MMT PLUG FROM THE SMT RECEPTACLE.

- 1- INSERT THE TOOL UNDER THE RIGHT ANGLE MMT PLUG AS SHOWN.
- 2- PULL OFF IN THE VERTICAL DIRECTION TO EXTRACT THE RIGHT ANGLE MMT PLUG.

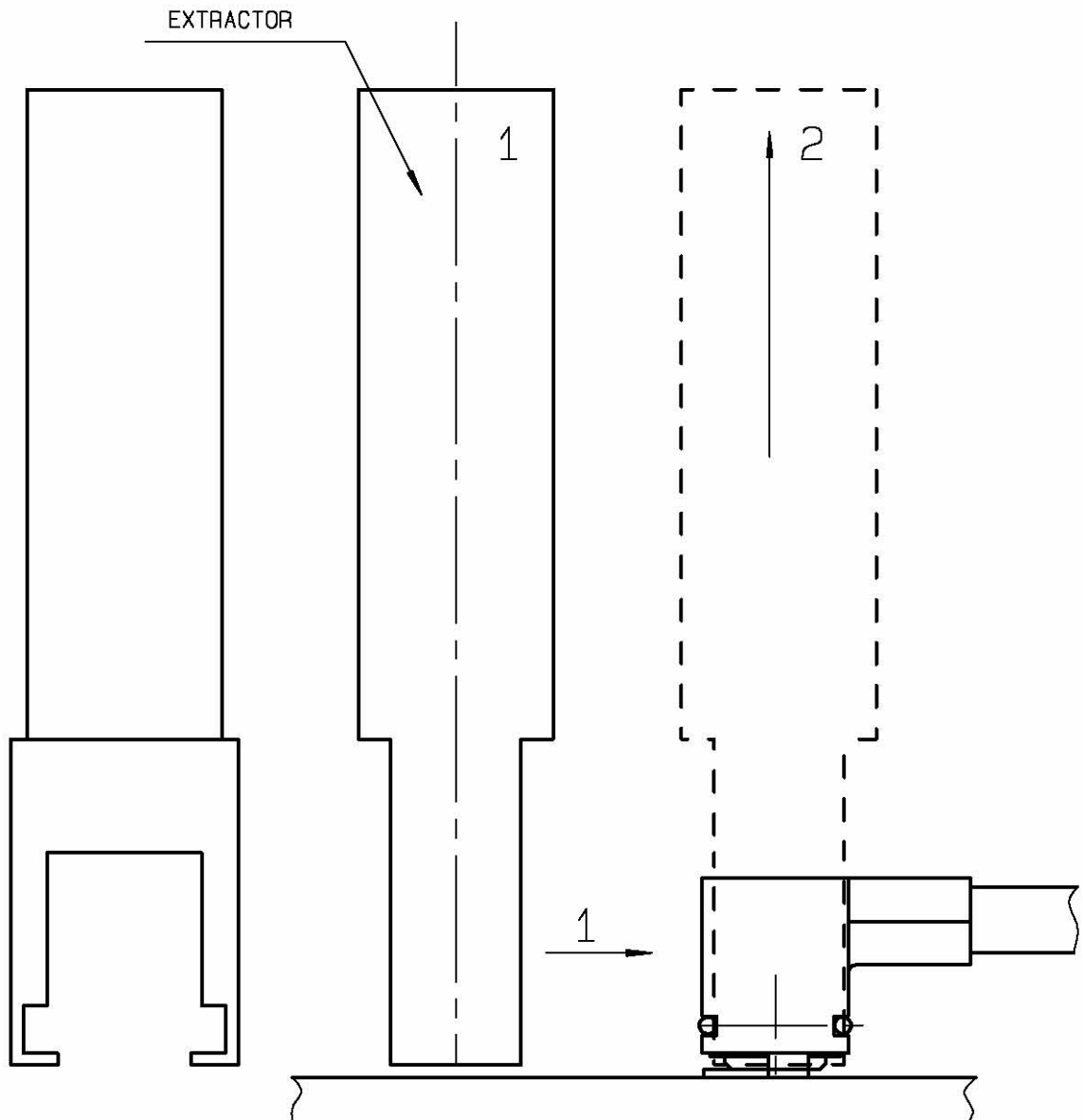

Issue : 0729 A

In the effort to improve our products, we reserve the right to make changes judged to be necessary.

**RADIALL**®